

KATAOKA

KSW-Series

Spiral Washer

Robust spiral conveyor system used in various applications from bolts and nuts to recycle plant operations.



- Highly rigid spiral conveyor system.
- Robust washing system that provides flexible support in a widerange of fields.

Options that match your washing system requirements

- Add rinse tank and anti-rust tank
 - Add ultrasonic tank
- Support available for other multi-tank systems

■ Dimensional drawing **KSW-500**

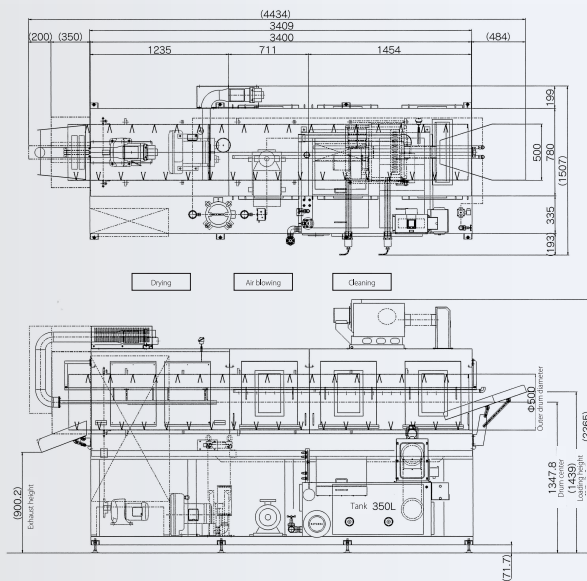

■ Main components

Description	
Drum drive motor	Oil catcher
Washing pump	Water level detector
Bag filter	Plug-type electrical heater
Filter clogging PS	Exhaust system
Filter regulator	Tank temperature controller
Hot air generator	Drying chamber temperature controller

Drum diameter..... ϕ 500mm
 Spiral pitch 200 mm.....200mm
 Drum speed.....2 to 4 rpm

■ Dimensional drawing **KSW-750**

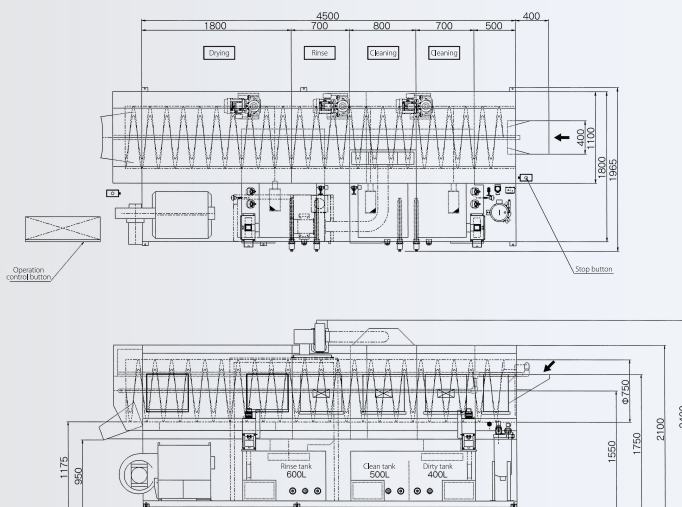

■ Main components

Description	
Drum drive motor	Oil catcher
Washing pump	Water level detector
Bag filter	Plug-type electrical heater
Filter clogging PS	Exhaust system
Filter regulator	Filter pump
Hot air generator	Rinse pump

Drum diameter..... ϕ 750 mm
 Spiral pitch 200 mm.....200mm
 Drum speed.....2 to 4 rpm

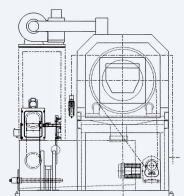

*The appearance and specifications are subject to change without previous notice in order to improve performance.